

ACUMEN TECHNOLOGIES, INC.

SERIES 4000 CHAIN LUBRICATION SYSTEM

ACUMEN TECHNOLOGIES' State-of-the-art SERIES 4000 Chain Lubrication System dispenses lubricant to chains in a continuous pinpoint flow. This allows lubrication of the chain in any application without overspray or oil contamination of your product or environment. This system is designed to dispense oil only or air/oil spray .

FEATURES

- 5 gallon reservoir with High/Low/Pump protect level indication.
- High capacity oil delivery.
- NEMA12 electrical housing.
- 1/2 HP AC Motor
- Miniature piston pump, 5 piston design.
- Will handle any nozzle quantity.
- Powder coat baked paint finish
- Multiple regulators available to balance tubing run distances.
- Low Oil - Low Air Pressure Switches Standard
- Capable of spraying different chains, both continuous and pulse spray with a single system.

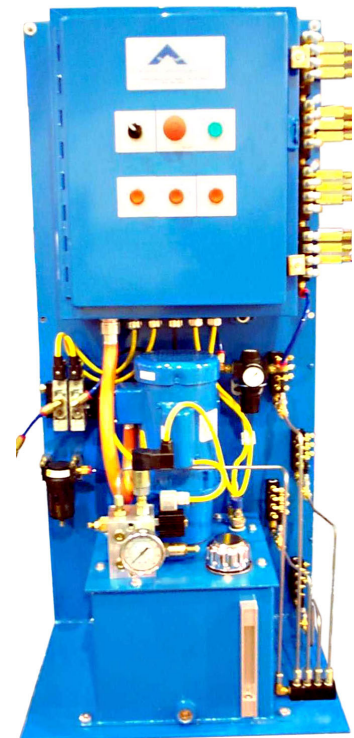

ADVANTAGES

- **Extended Chain Life:** Proper delivery of lubricant to the sliding and rolling elements of the chain provides extended life of the chain pins, links, sliding wear surfaces, and bearings.
- **Power Savings:** Proper lubrication of the chain sliding surfaces and rolling wheel components reduces friction. This reduction in friction will result in a power savings by a decrease in amperage draw of the drive motor.
- **Consistent Delivery:** No puddling of oil on the chain or product as with conventional drip or brush lubricators.
- **Reduced oil consumption:** By applying the lubricant in small controlled quantities, where it's needed, when it's needed, oil reductions of 50% to 90% are achieved over conventional chain lubrication systems.
- **Precise Volume Control:** Positive displacement piston pump with high speed control valve delivers precise amount of lubricant to the nozzle.
- **Accurate Delivery:** Strategically positioned nozzles (no bent tubes) direct lubricant to the wear points with no overspray.

SPECIFICATIONS

Electrical:

NEMA 12/13 Enclosure
 110/120 VAC 50/60 Hz
 24 VDC

Pneumatic:

Inlet: 3/8 NPT to be supplied with 3/8" pipe or 1/2" steel tubing
 Pressure: 60PSIG min / 120PSIG max
 Filter: High Capacity 5 Micron

Oil Reservoir:

2000ml Standard with Central Fill Adapter
 1,5,10,30 Gallon Available
 Low Reservoir Level Float Switch
 Max switching power 70VA
 Switch contact: SPST NO
 Voltage: 120 VAC or 24 VDC

Fluids Delivered:

Oil and similar fluids 70 SSU - 3000 SSU

Nozzles:

Acumen nozzles are available for a wide variety of spray patterns:
 Pin Point
 360 degree
 Cone Spray
 Flat Spray
 Special Application Nozzles

Injector Pump Displacements:

0.015ml (1/2 Drop)
 0.030ml (1 drop)
 0.060ml (2 Drop)

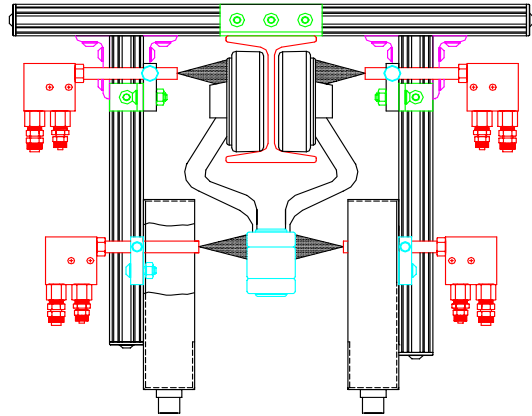

Four Nozzle - Two Continuous / Two Intermittant Spray

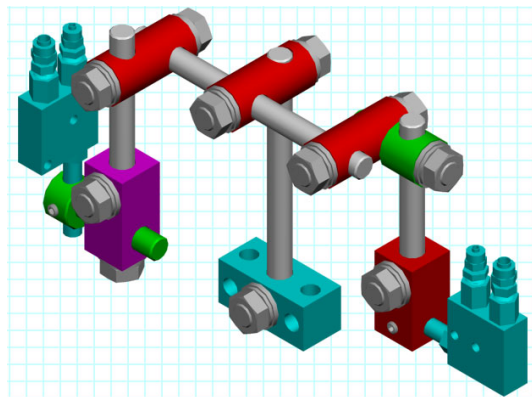

Modular Aluminum Bracket System

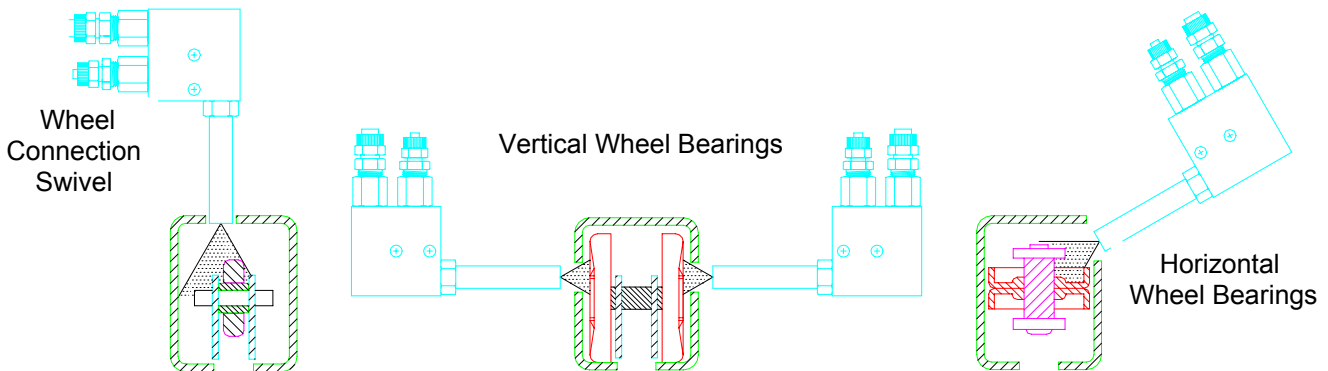

**Overhead Power Chain Conveyor - Enclosed Track
 Four Nozzle Continuous Spray**

DISTRIBUTED BY: